

FTS TWIN SCREW PUMP

DIMENSIONS

TYPE	Inlet	Outlet	A	B	C	D	D1	E	E1	F	G	J	K	M	N	H
FTS.A.18	1,5"-2"	1"-1,5"	436	385	265	22	6	122	52	178	127	145	12	115,5	95	225
FTS.A.26	1,5"-2"	1"-1,5"	436	385	265	22	6	122	52	178	127	145	12	115,5	95	225
FTS.B.26	2,5"-3"	2"-3"	589	520	354	28	8	181	57,5	225	162	180	12	190	125	280
FTS.B.36	2,5"-3"	2"-3"	589	520	354	28	8	181	57,5	225	162	180	12	190	125	280
FTS.C.32	3"-4"	3"-4"	720	634	411	42	8	196	73	322	206	240	18	300	194	376
FTS.C.48	3"-4"	3"-4"	720	634	411	42	8	196	73	322	206	240	18	300	194	376

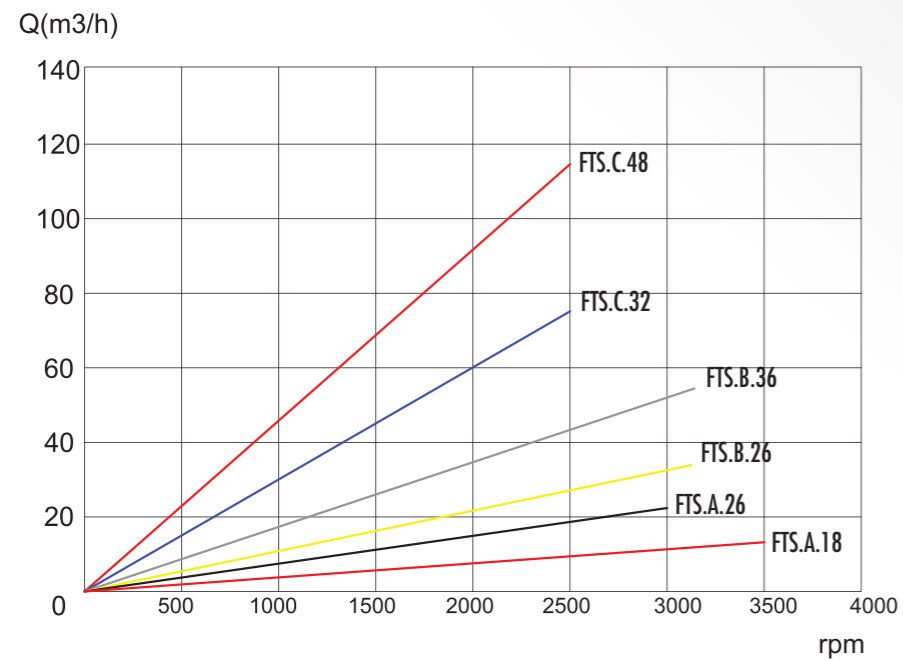
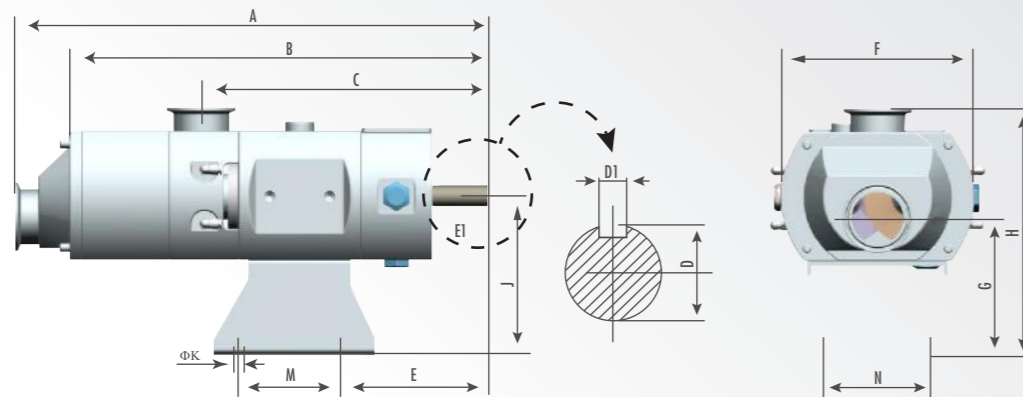

FTS TWIN SCREW PUMP



YOUR SOLUTION PARTNER

FTS TWIN SCREW PUMP

APPLICATION

- » Twin screw pumps are predestinated by their operation mode and the construction for low shearing and smooth handling of sensitive products.
- » The axial transporting movement, without changing direction, as well as the non-contacting intermeshing screws, provide optimum results

DESIGN AND FEATURES

- » Max. Flow : 110m³/h
- » Max. Particles : 23mm
- » Max. Pressure : 20bar
- » Speed range : 10-3500 rpm
- » Surface treatment : Ra ≤ 0,6µm ; EP=RA0,4 µm
- » Working temperature : -40°C to 150°C

ADVANTAGES

- » Pumped capacity proportional to speed
- » Compact construction
- » Direct drive without speed-reducer possible
- » For almost all media and fluids
- » High viscosities possible
- » Low pulsations
- » Low noise level
- » Dry running possible
- » Constant flow on varying pressures and volumes
- » Change of pumping direction - simple
- » Pumping elements - simple to replace
- » Easy maintenance
- » Wide range of applications
- » Self-priming

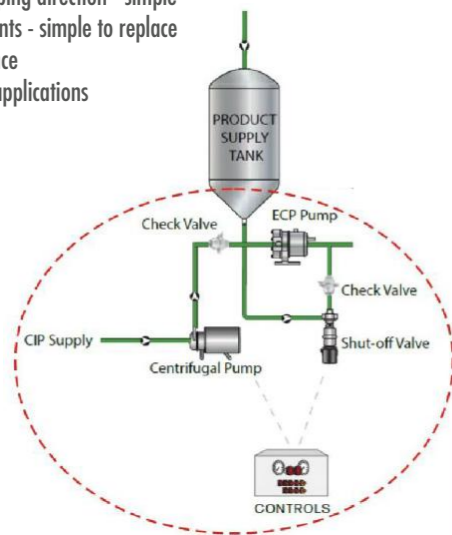

» Traditional System
Other Solutions CIP cleaning and media delivery configuration
Many valves, pumps and pipes are required

WORKING PRINCIPLE

- » The screw pair rotates inside the pump Enclosure, creating several separate chambers and pushing the fluid trapped inside in accordance with the progression of the screws pitch. The flow rate is particularly uniform and pulsation-free, and the pumped fluid flows in axial direction (not circumferentially, as it happens in the centrifugal pumps) The result of the screws rotation is a gentle movement of the displaced volume, in not turbulent conditions, making it ideal for handling shear-sensitive fluids or liquids easily subject to emulsification

MATERIALS

- » Parts in contact with the product : AISI316 L
- » Other Steel parts : AISI304
- » Gaskets : EPDM/FKM
- » Mechanical Seal : SIC/C/EDPM, SIC/C/FKM, TC/TC/EPDM, TC/TC/FKM

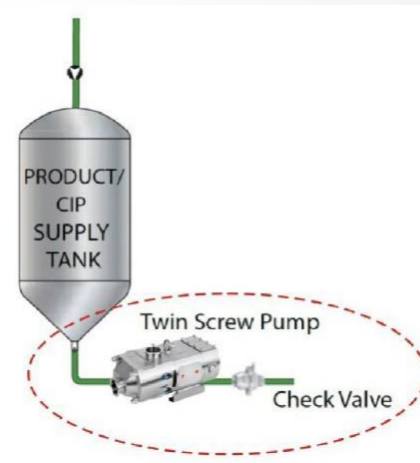

» Twin screw pump system
Screw pump Solutions CIP cleaning and media delivery configuration
Less valves, pumps and pipes

FTS TWIN SCREW PUMP

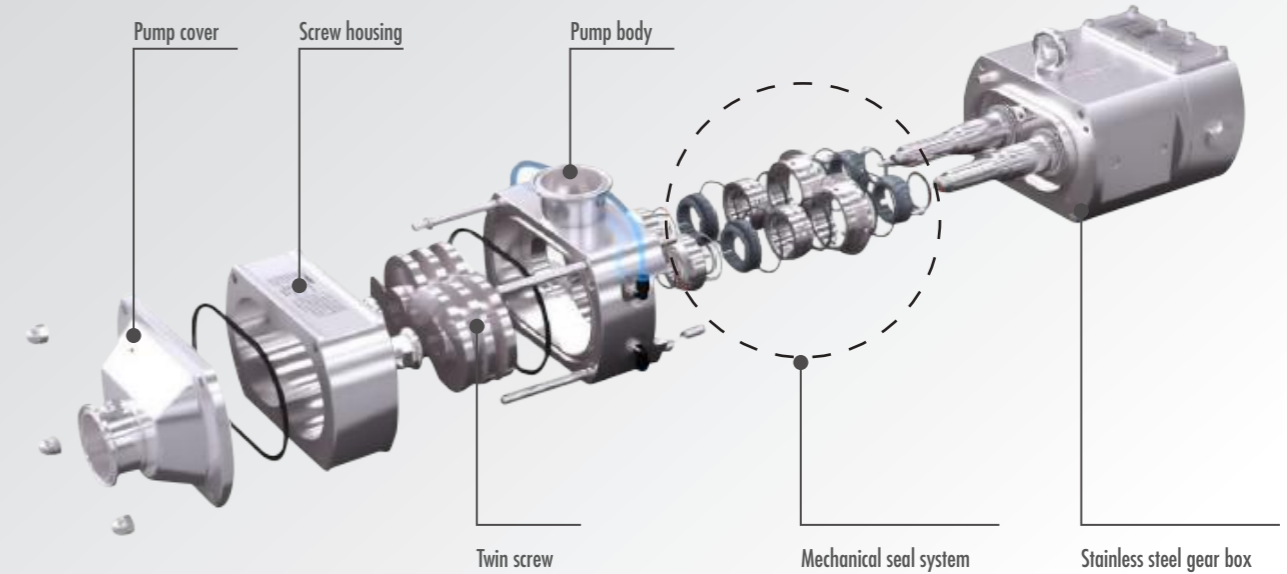

MOTOR DIRECT-CONNECTED SCREW PUMP SELECTION TABLE

Model	Screw Spacing (mm)	Pressure (bar)	Motor (kw)	Max.Solid (mm)	Flow per rotation (L/r)	Suggested speed range (r/min)	Suggested flow range (m ³ /h)	Pump head inlet	Pump body outlet	Net Weight (kg)
FTS A.26	26	3	2.2	12.5	0.13	100-1450	0,78-11,3	1,5"-2"	1,5"-2"	80.9
		5	3							84.9
		8	4							90.9
		11	5.5							123.9
		15	7.5							134.9
FTS B.26	26	4	4	12.5	0.2	100-1450	1,2-17,4	2,5"-3"	2,5"-3"	152.7
		8	5.5							163.7
		12	7.5							218.7
		18	11							233.7
FTS B.36	36	3	4	17.5	0.29	100-1450	1,74-25,2	2,5"-3"	2,5"-3"	152.7
		7	5.5							163.7
		10	7.5							218.7
		15	11							233.7
FTS C.32	32	4	7.5	15.5	0.53	100-1450	3,18-31,8	3"-4"	3"-4"	314.7
		8	11							329.7
		12	15							374.7
		18	18.5							387.7